

RAPTOR RAIL™ 3in 18in 32in

Package CONTENTS:

1. qty. 1 Raptor Rail™
2. qty. 2 Raptor Rail™ end caps
3. qty. 2 TimberLok® Anchors

*Pictured with Raptor Rail™ 3in

1. Always secure your Raptor Rail™ to a Sturdy Surface and ensure the rail is firmly mounted before installing any Raptor™ Components.
2. Locate Wall Stud to ensure maximum mounting strength. (fig.1)
3. Position the Raptor Rail™ to fit desired mounting location and ensuring the mounting screws will secure into a wall stud. Raptor Rails™ are designed to be used when anchored into a wall stud.
4. Mark the mounting hole locations with a pencil.
5. Pre-drill the mounting holes with a 5/32 drill to ensure you have located a wall stud and that the mounting screws will not split the wall stud during install.
6. Secure the Raptor Rail™ with the supplied TimberLok® mounting screws using a 5/16 socket. Install by hand with a ratchet.
7. Install Raptor Mounts™ and/or Raptor Brackets™ to fit your desired configuration for your weapon.
8. After you configure your Raptor™ components and test fit your weapon then install the second Raptor Rail™ end cap by aligning the two pins with the corresponding holes at the end of the Raptor Rail™. (fig.2)

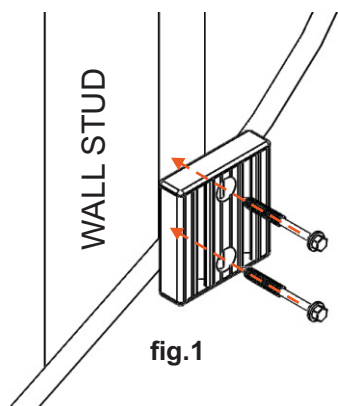

fig.1

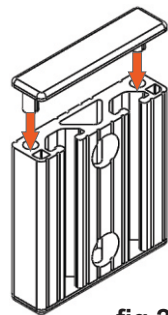

fig.2



Raptor Rail™ 3in
RPN: 1070



Raptor Rail™ 18in
RPN: 1075



Raptor Rail™ 32in
RPN: 1080

WARRANTY REGISTRATION - go to: www.usaraptor.com and select Warranty Registration

WARNING



CUIDADO

- Always ensure Firearms are unloaded and safety is on prior to handling.
- Always maintain firearms in accordance with local, state and federal laws.
- Product is not intended for use by children (product is not a toy).
- Raptor Products, Inc. assumes no liability for unauthorized use of Raptor Products or the actions resulting thereof.
- Raptor Products, Inc. assumes no liability for authorized use of Raptor Products or the actions resulting thereof.
- Consumer assumes all liabilities for any action resulted from the use or misuse of Raptor Products at time of Purchase.
- Product is intended for securing to sturdy, substantial mounting surface such as a building wall stud, Raptor Products, Inc. assumes no liability for improper mounting to substrates that cannot handle the required forces.
- Do Not open or modify the product.
- Do Not Use power tools as this may result in over tightening.
- Do Not Use this product unless all screws and hardware are properly tightened.
- Check that all screws and hardware is tight every three months or as needed.
- Do not disassemble or attempt to service this product, as there may be adverse effects to the performance of the product.
- This product is safe under normal and reasonably foreseeable conditions.
- Do not immerse the product in any liquid or expose to heat, cold or moisture.
- Raptor Products are intended solely for the use with corresponding products.
- Abuse or Misuse of products may result in dangerous consequences, faulty product performance or other unintended consequences.
- Raptor Products, Inc. assumes no liability for such misuse of Raptor Products.
- Customer assumes all liability for bodily harm, death and/or property damage resulting from the use of Raptor Products.
- Customer assumes all liability for bodily harm, death and/or property damage resulting from the firearms/items that are retained by Raptor Products.

RAPTOR PRODUCTS, INC. RETURN POLICY

- Items can be returned within 45 days with copy of the receipt.
- Items must be purchased through www.USARAPTOR.COM to be eligible for return or exchange through Raptor Products, Inc.
- The item must be in its original packaging and free from wear or damage.
- There are no returns on final sale or discontinued items.
- The customer is liable for the return shipping to Raptor Products, Inc.
- Raptor Products, Inc. will send any requested and approved exchange items after the original merchandise is received at the warehouse.

Raptor Products, Inc. LIMITED HARDWARE PRODUCT WARRANTY

Subject to terms, conditions and limitations outlined below, Raptor Products, Inc. guarantees its products against defects in materials and workmanship that adversely affect their operation for a period of one (1) year from the date of their original purchase by the initial consumer. This warranty is valid only for products purchased and used in the United States of America, its territories and possessions and Puerto Rico. This warranty only becomes effective if activated by the original consumer purchaser within 30 days of the purchase date, by completing the product warranty registration for your Raptor Products, Inc. products at www.usaraptor.com. Raptor Products, Inc. reserves the right, at its sole discretion, to accept proof of purchase in lieu of a completed warranty card. To make a claim under this warranty, contact Raptor Products, Inc. Via the CONTACT US Information link Located at www.USARAPTOR.COM for instructions on how to return your products. Do not return your Raptor Products for service without prior authorization. For your records, save your original receipt with these instructions/manual. Raptor Products brand packaging is designed to ensure product protection. Save original packaging in case of warranty shipping.

LIMITATIONS OF WARRANTY (The warranty will be void if any of the following occur):

1. The instructions in the User manual and/or online are not followed;
2. Your Raptor Product(s) or any of its parts are altered or modified from their original state;
3. Damage is caused by misuse, abuse or improper maintenance;
4. Your Raptor Product(s) has been disassembled beyond the instructions state for normal install or use;
5. The period of time has elapsed outside the stated warranty coverage time;
6. There are no warranties which extend beyond the description on the face hereof;
7. The sole and exclusive remedy pursuant to this warranty is the repair or replacement of your Raptor Products, at the sole discretion of Raptor Products, Inc.;
8. The implied warranties of merchantability and fitness for a particular purpose are expressly disclaimed;
9. All disclaimers and limitations of liability shall still apply even if the limited remedy of repair and replacement fails of its essential purpose;
10. In states where permitted, Raptor Products, Inc. assumes no liability for incidental or consequential damage or for incidental expenses;
11. Any action against Raptor Products, Inc. based on an alleged breach of this warranty must be brought within one (1) year of the claimed breach;
12. Raptor Products, Inc. shall not be liable for any harm and/or damages, whether direct, incidental or consequential to the products, persons or property;
13. This warranty gives you specific legal rights, and you may also have other rights which vary from state to state;
14. Please review the complete warranty information immediately prior to and after any purchase of Raptor Products;
15. Raptor Products, Inc.'s liability for breach of warranty shall be limited to repair or replacement of your Raptor Products, at the sole discretion of Raptor Products, Inc.;
16. Raptor Products, Inc. reserves the right to modify this warranty at any time.
17. Raptor Products, Inc. reserves the right to modify this warranty at any time.

Printed in the USA for: Raptor Products, Inc.

visit www.usaraptor.com for the latest product warnings and warranty registration



visit usaraptor.com



RAPTOR

SECURE DISPLAY ACCESS PRODUCTS



© 2015 Raptor Products, Inc. | All Rights Reserved